



5200 W. CENTURY BLVD.
LOS ANGELES, CA 90045

**Smooth / Wood Grain / White Wood Grain
Rustic / Mahogany
Series Fiberglass Door
IN SWING / OUT SWING
"NON-IMPACT"**

GENERAL NOTES

1. This product has been evaluated and is in compliance with the 2010 Florida Building Code (FBC) structural requirements excluding the "High Velocity Hurricane Zone" (HVHZ).
2. Product anchors shall be as listed and spaced as shown on details. Anchor embedment to base material shall be beyond wall dressing or stucco.
3. When used in areas requiring wind borne debris protection this product is required to be protected with an impact resistant covering that complies with Section 1609.1.2 of the 2010 FBC.
4. For 2x stud framing construction, anchoring of these units shall be the same as that shown for 2x buck masonry construction.
5. Site conditions that deviate from the details of this drawing require further engineering analysis by a licensed engineer or registered architect.

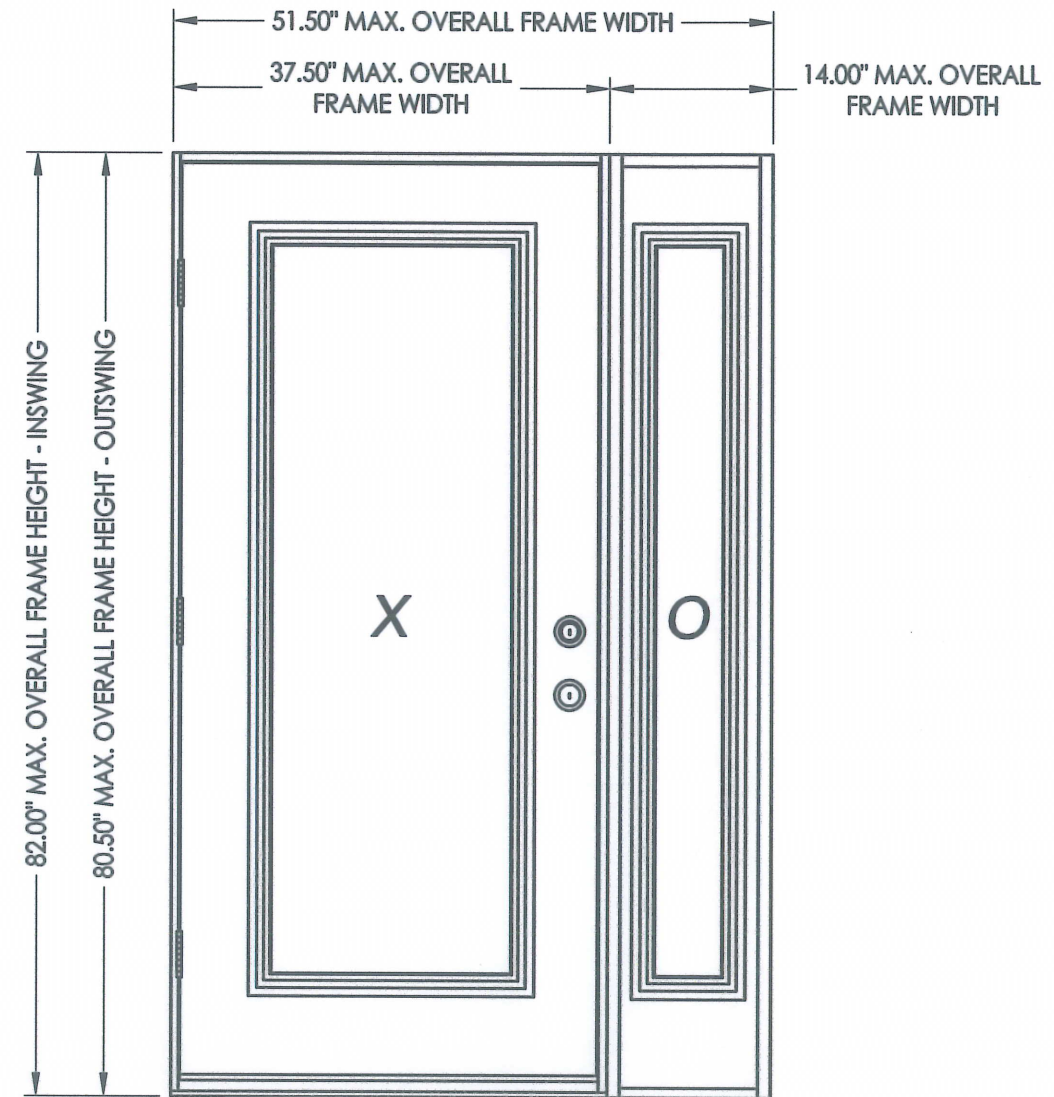

TABLE OF CONTENTS	
SHEET #	DESCRIPTION
1	Typical elevation, design pressures, & general notes
2	Door panel details
3	Sidelite panel details
4	Horizontal cross sections
5	Vertical cross sections
6	Vertical cross sections
7	Buck and frame anchoring - 2X buck masonry construction
8	Frame anchoring - 1X buck masonry construction
9	Bill of materials, glazing detail & components

SWING	OVERALL FRAME DIMENSION	DOOR D.L.O. DIMENSION	SIDELITE D.L.O. DIMENSION	GLASS TYPE	DESIGN PRESSURE (PSF)	
					POSITIVE	NEGATIVE
IN SWING	51.50" x 82.00"	21.00" x 63.00"	5.87" x 63.00"	G1	+50.0	-50.0
OUT SWING	51.50" x 80.50"	21.00" x 63.00"	5.87" x 63.00"		+50.0	-60.0

Documents Prepared By:

RW BUILDING CONSULTANTS, INC.
P.O. Box 230 Vairico FL 33595
Phone No.: 813.659.9197
Florida Board of Professional Engineers
Certificate of Authorization No. 9813
Lyndon F. Schmidt, P.E. No. 43409

PRODUCT: PLASTPRO INC. FIBERGLASS DOOR
PART OR ASSEMBLY:
TYPICAL ELEVATION, DESIGN PRESSURES & GENERAL NOTES

NO.	DATE	BY	REVISIONS

DATE: 02/16/12
SCALE: N.T.S.
DWG. BY: JK
CHK. BY: LFS
DRAWING NO.: FL-15213.10
SHEET 1 OF 9

R:\A - Projects\Project Folders\proj 1501 - 1600\PF 1587\D. RWBC Drawings\2010\FL-15213\9-11.dwg, FL-15213.10

R:\A - Projects\Project Folders\proj 1501 - 1600\PF 1587\D. RWBC Drawings\2010\FL-15213.9-11.dwg, 4.10

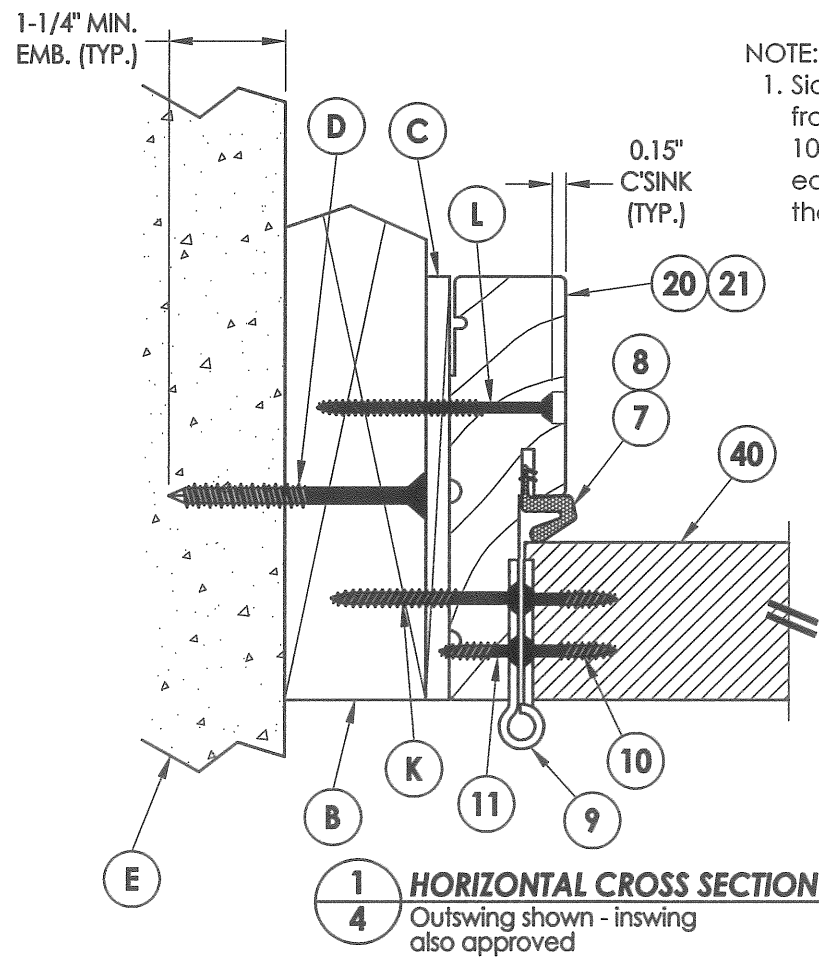
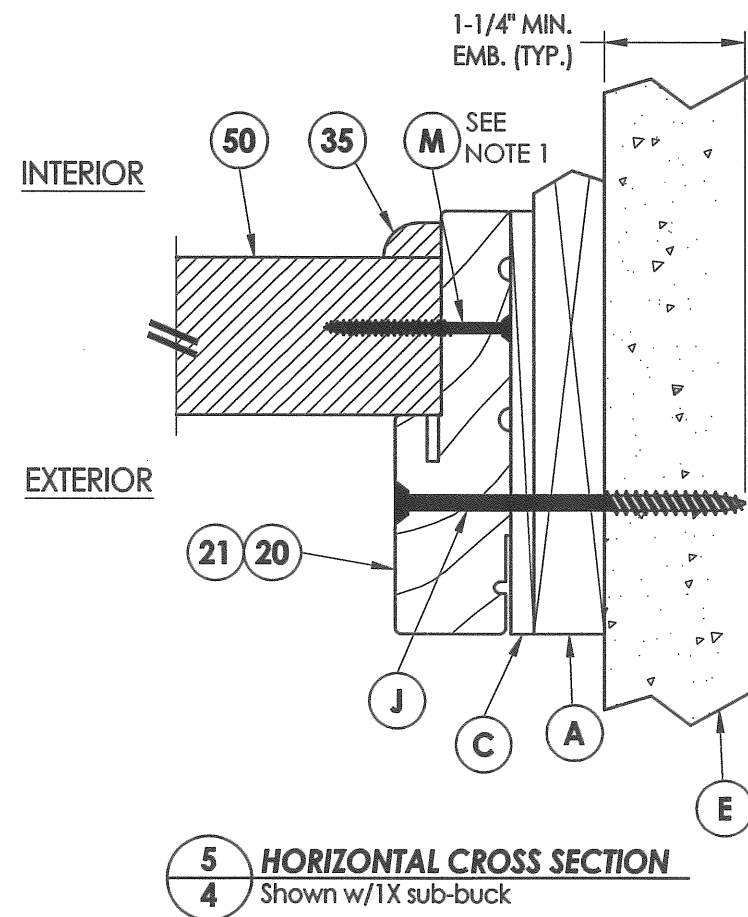
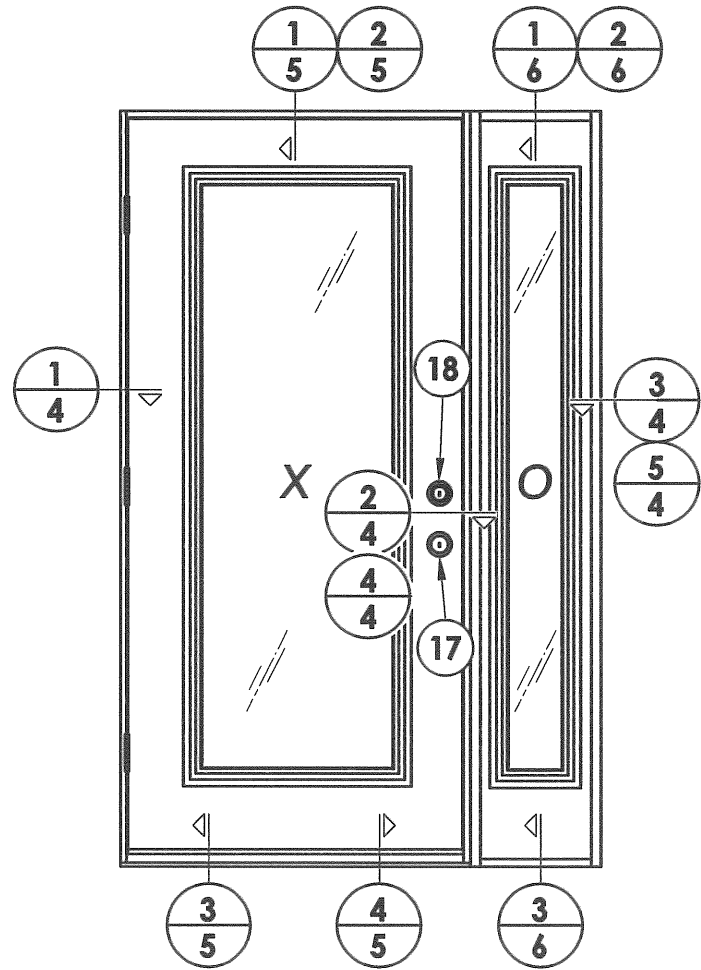
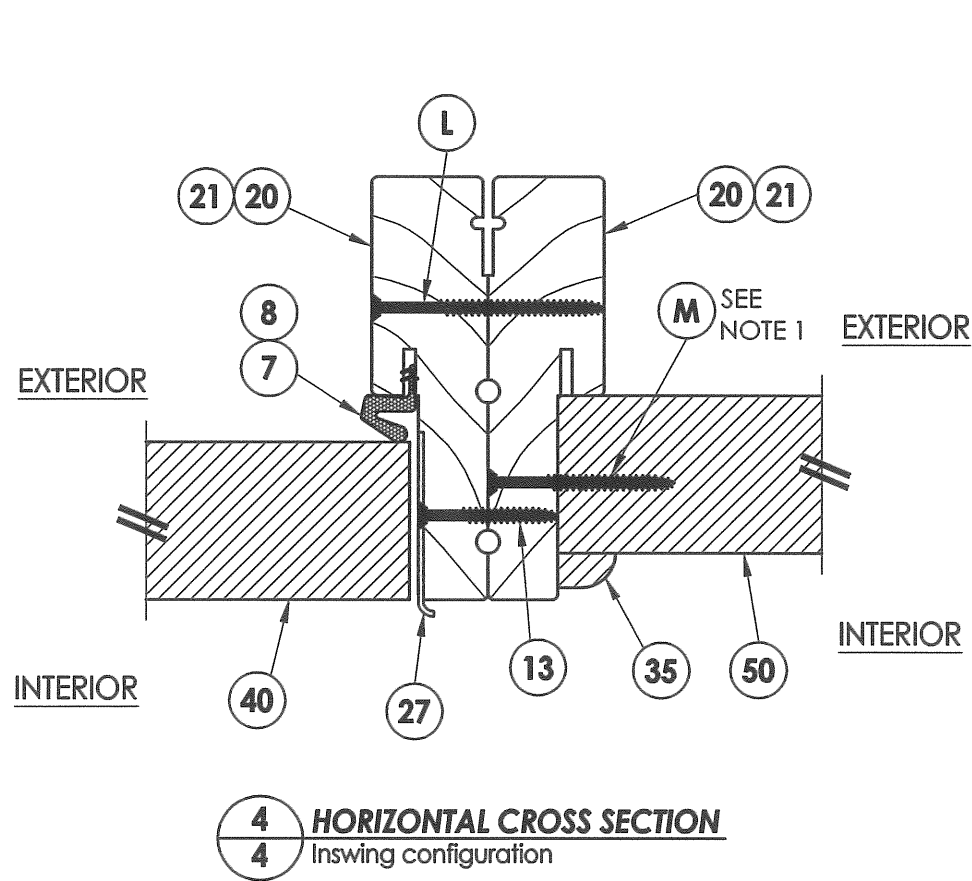

NOTE:
1. Sidelite panel secured to the sidelite frame with (4) of item #M located 10", 30.5", 51" and 71.5" from top of each jamb and (2) of item #M in the head, 3" from each end

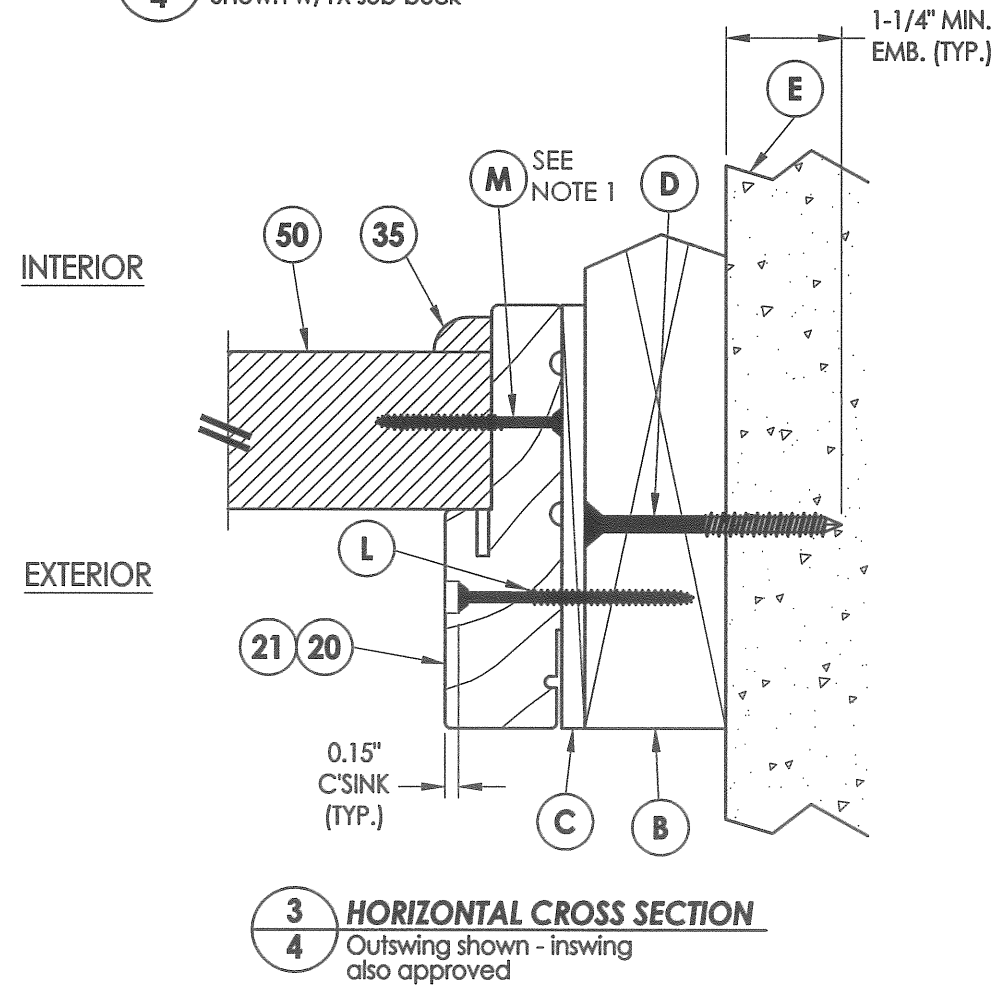
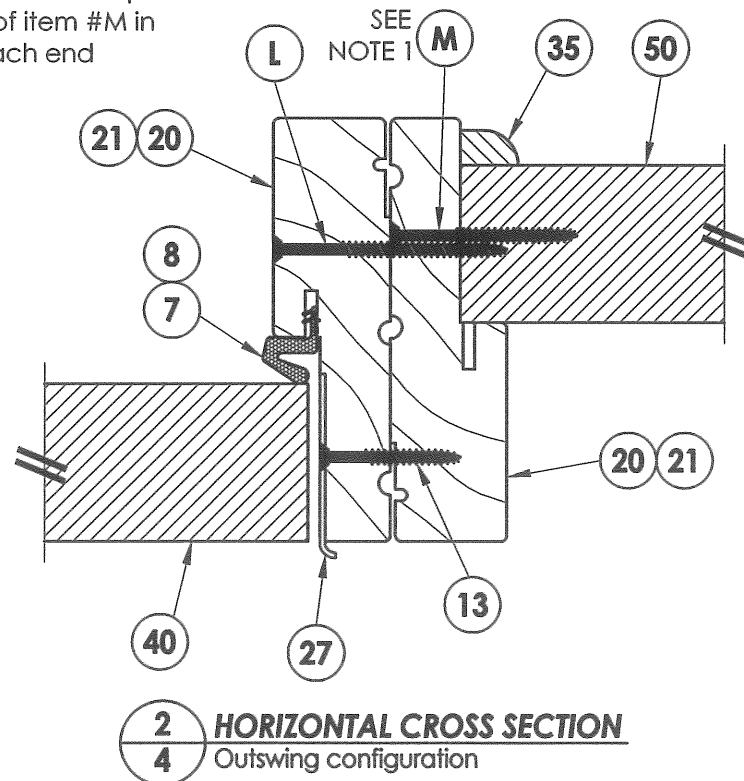

Documents Prepared By:
RW BUILDING CONSULTANTS, INC.
P.O. Box 230 Valrico FL, 33595
Phone No.: 813.659.9197
Florida Board of Professional Engineers
Certificate Of Authorization No. 9813
Lyndon F. Schmidt, P.E. No. 43409

PRODUCT:
PLASTPRO INC.
FIBERGLASS DOOR
PART OR ASSEMBLY:
HORIZONTAL CROSS SECTIONS

NO.	DATE	REVISIONS	BY

DATE: 02/16/12
SCALE: N.T.S.
DWG. BY: JK
CHK. BY: LFS
DRAWING NO.: FL-15213.10
SHEET 4 OF 9

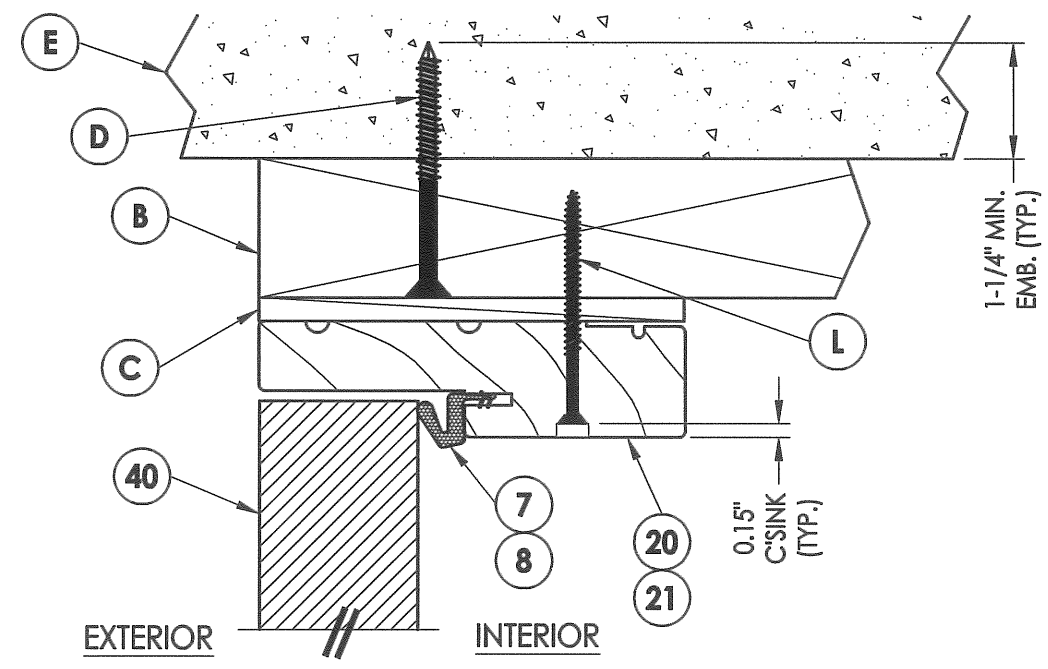

1 VERTICAL CROSS SECTION
5 Outswing shown - inswing also approved

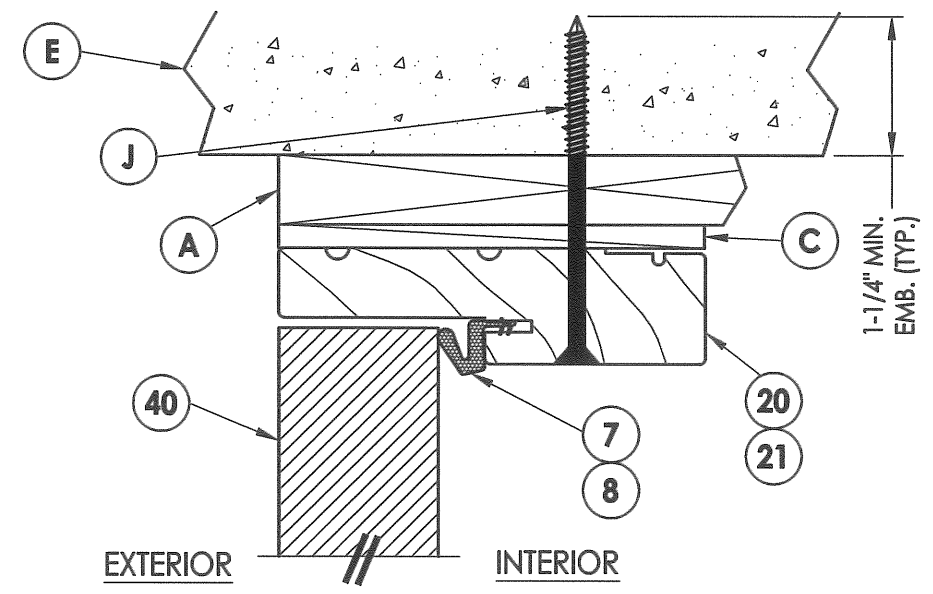

2 VERTICAL CROSS SECTION
5 Shown w/1X sub-buck

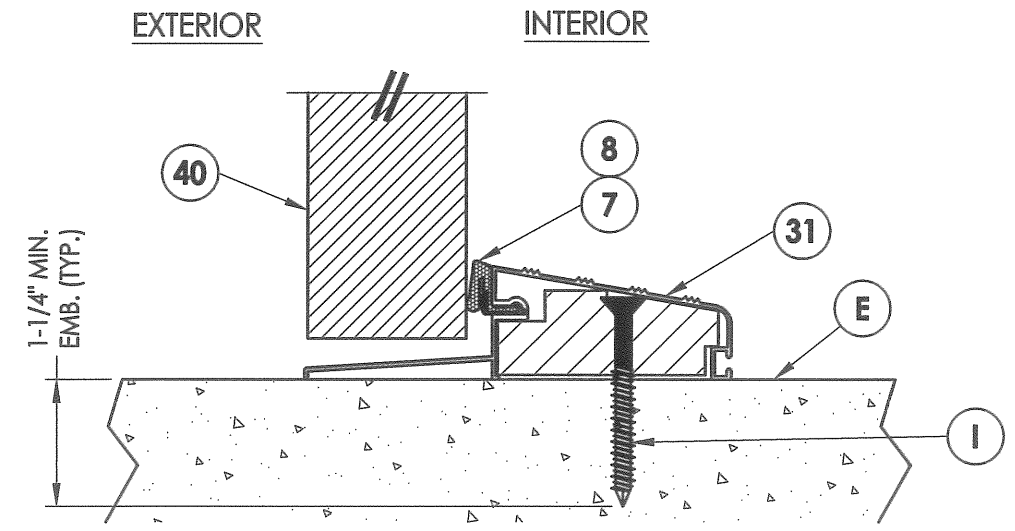

3 VERTICAL CROSS SECTION
5 Outswing configuration

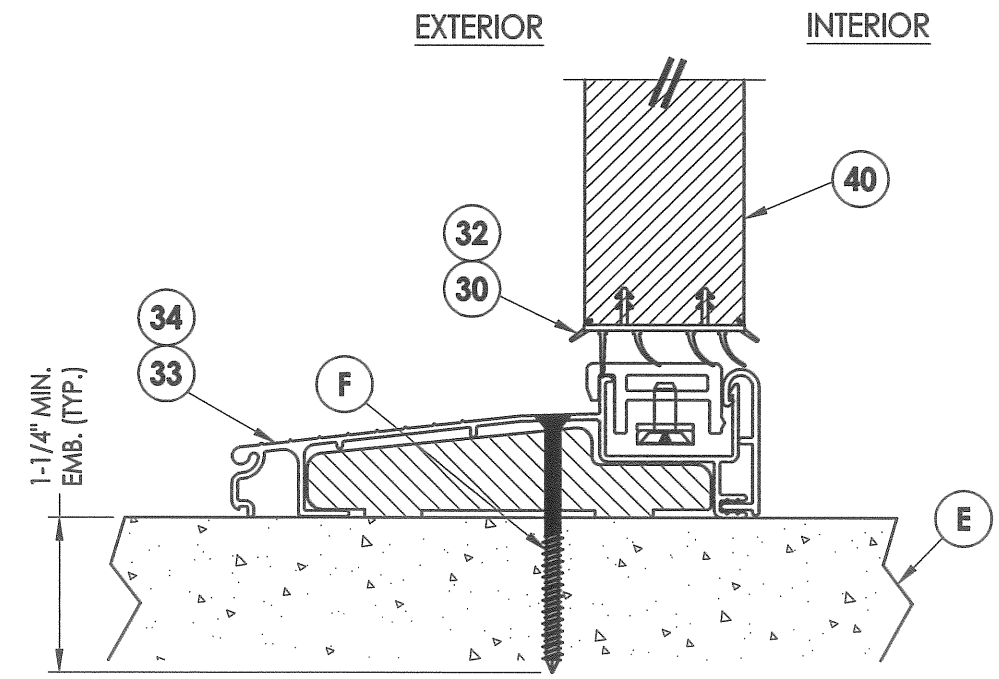

4 VERTICAL CROSS SECTION
5 Inswing configuration

Documents Prepared By: **RW** BUILDING CONSULTANTS, INC.
P.O. Box 230 Valrico FL 33595
Phone No.: 813.659.9197
Florida Board of Professional Engineers
Certificate Of Authorization No. 9813
Lyndon F. Schmidt, P.E. No. 43409

PRODUCT: **PLASTPRO INC. FIBERGLASS DOOR**
PART OR ASSEMBLY: **VERTICAL CROSS SECTIONS**

NO.	DATE	REVISIONS	BY

DATE: 02/16/12
SCALE: N.T.S.
DWG. BY: JK
CHK. BY: LFS
DRAWING NO.: FL-15213.10
SHEET 5 OF 9

© 2012 R.W. BUILDING CONSULTANTS INC.

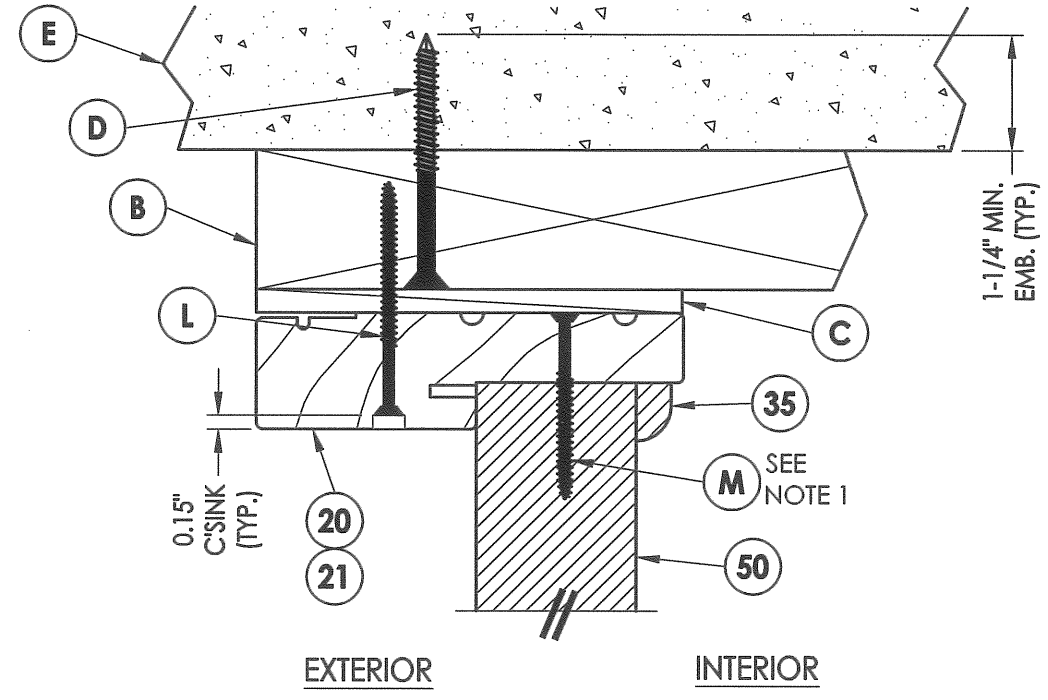

1 VERTICAL CROSS SECTION
6 Outswing shown - inswing also approved

NOTE:
 1. Sidelite panel secured to the sidelite frame with (4) of item #M located 10", 30.5", 51" and 71.5" from top of each jamb and (2) of item #M in the head, 3" from each end

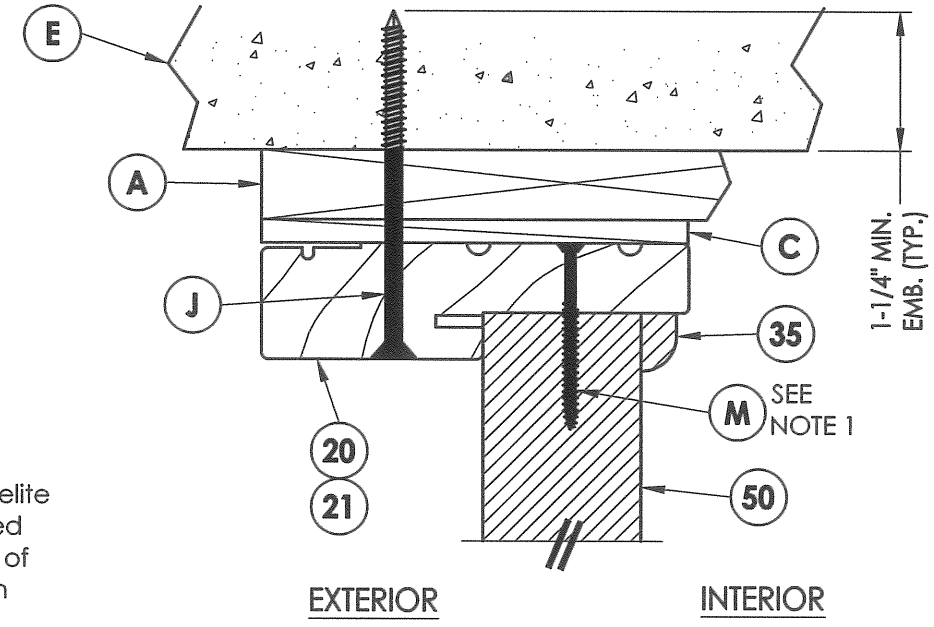

2 VERTICAL CROSS SECTION
6 Shown w/1X sub-buck

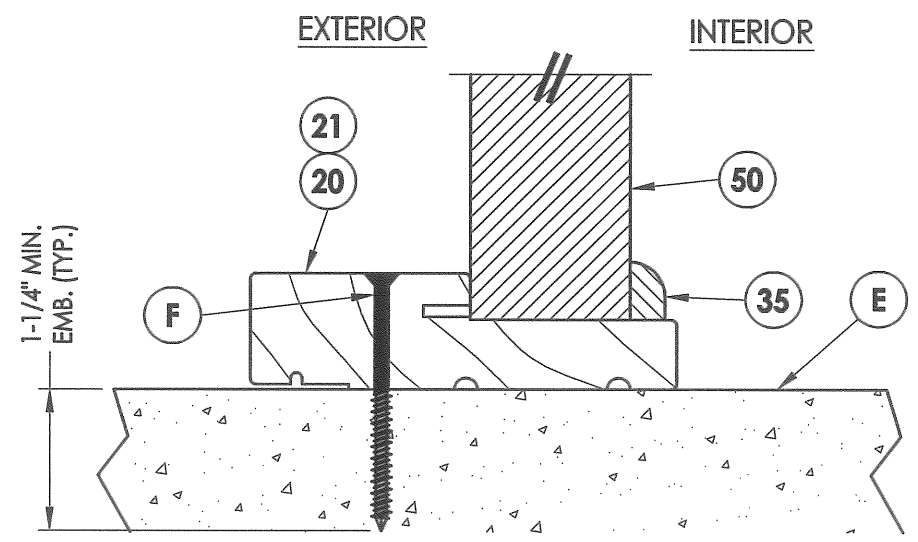

3 VERTICAL CROSS SECTION
6 Outswing shown - inswing also approved

Documents Prepared By: **RW BUILDING CONSULTANTS, INC.**
 P.O. Box 230 Vairico FL 33595
 Phone No.: 813.659.9197
 Florida Board of Professional Engineers
 Certificate of Authorization No. 9813
 Lyndon F. Schmidt, P.E. No. 43409

PRODUCT: **PLASTPRO INC. FIBERGLASS DOOR**

PART OR ASSEMBLY: **VERTICAL CROSS SECTIONS**

NO.	DATE	BY	REVISIONS

DATE: 02/16/12
 SCALE: N.T.S.
 DWG. BY: JK
 CHK. BY: LFS
 DRAWING NO.: FL-15213.10
 SHEET 6 OF 9

© 2012 R.W. BUILDING CONSULTANTS INC.

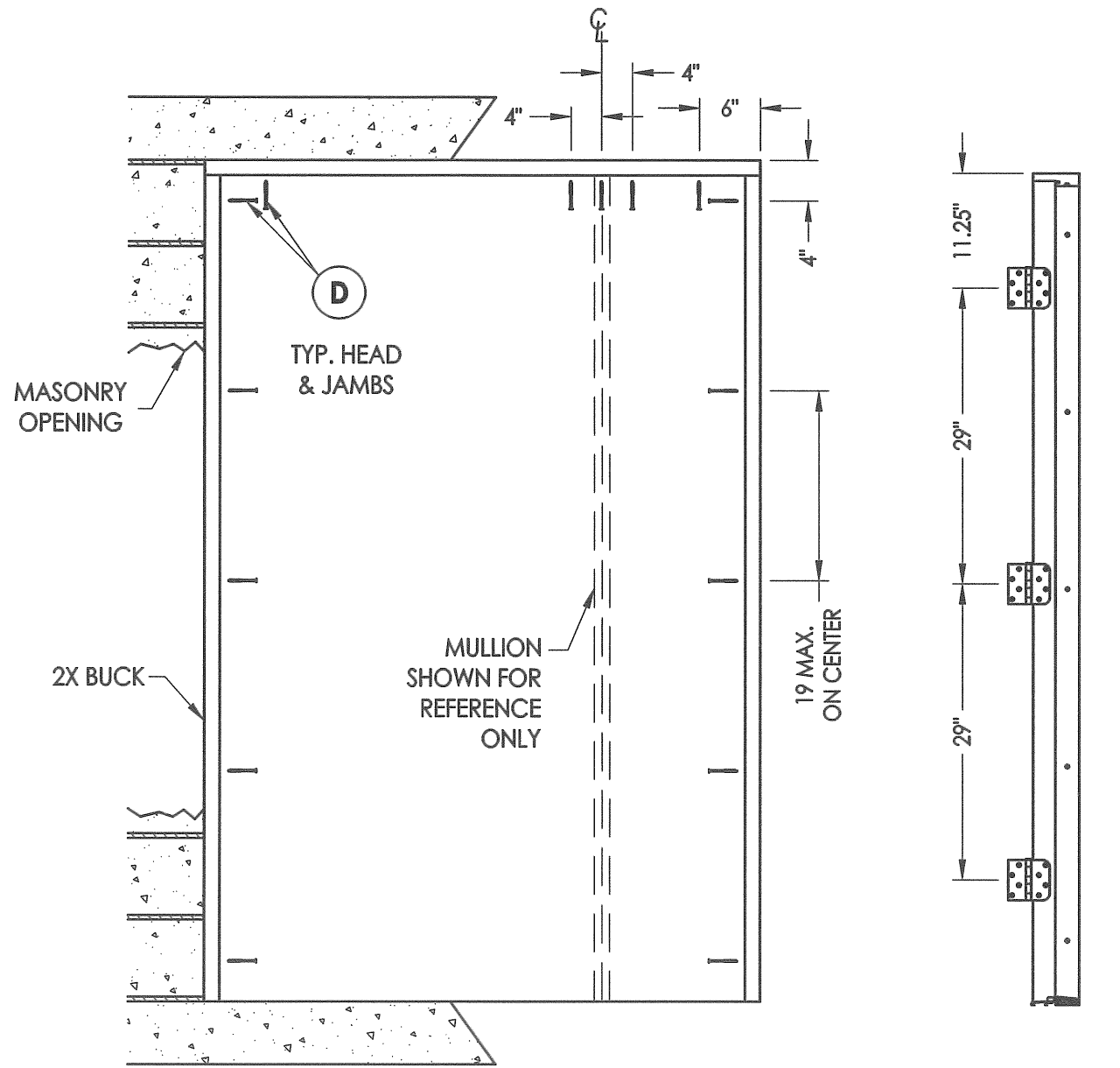

BUCK ANCHORING

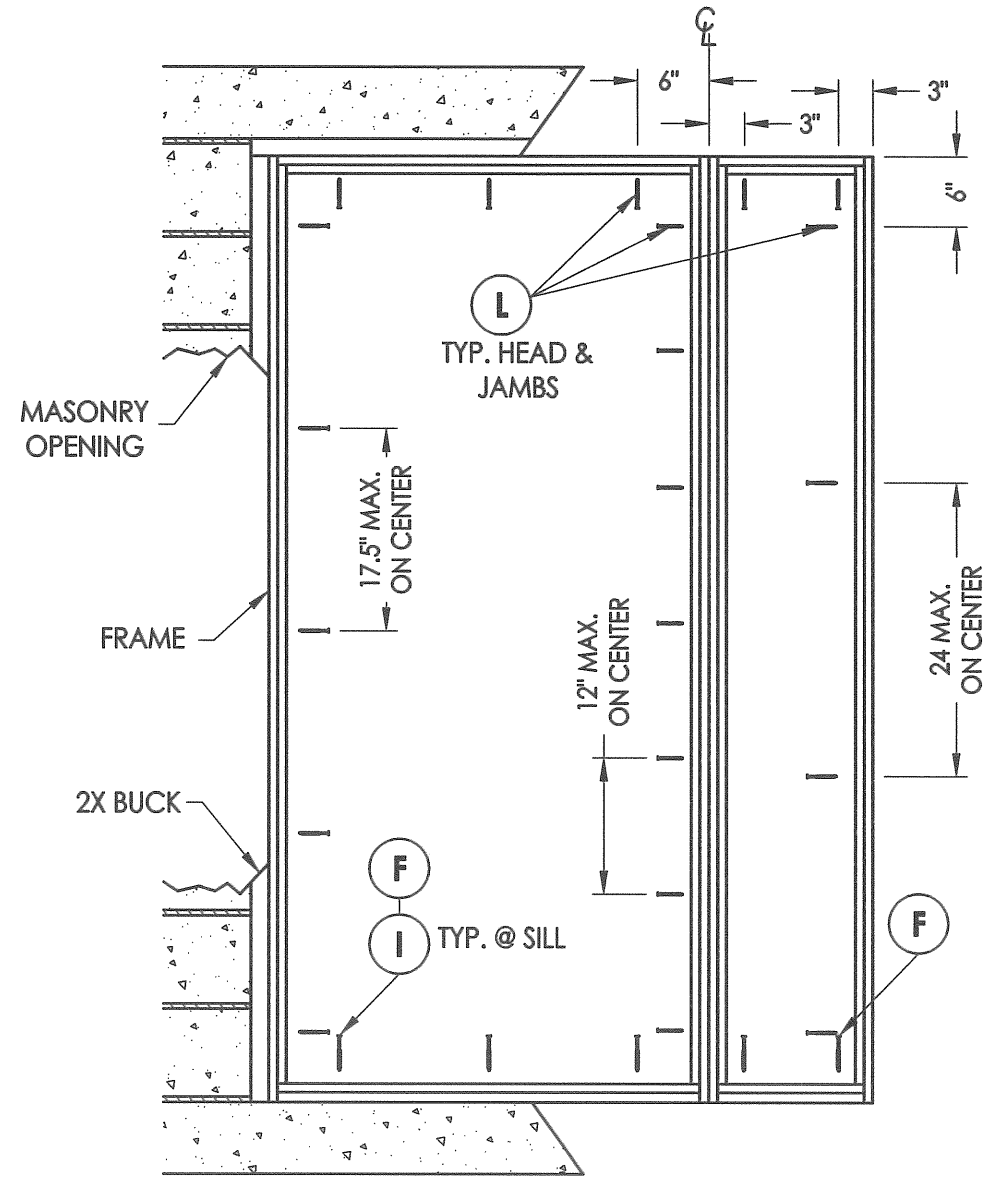

FRAME ANCHORING
Masonry 2X buck construction

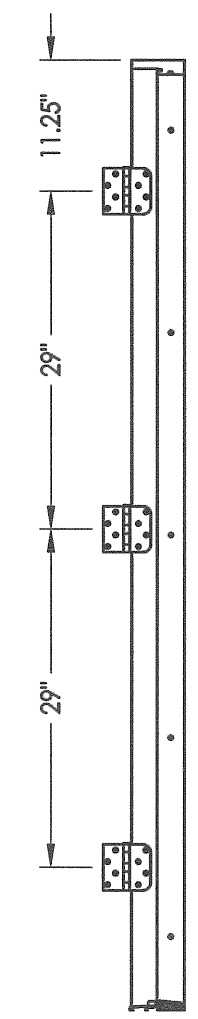

HINGE JAMB

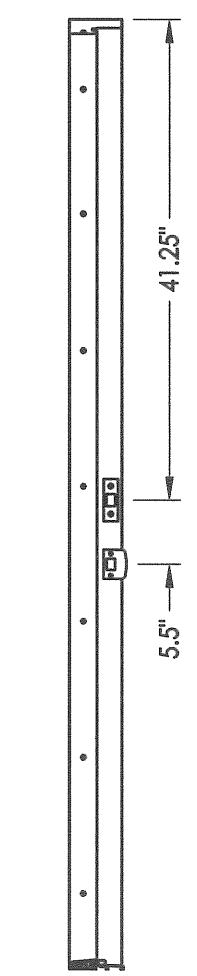

STRIKE JAMB

CONCRETE ANCHOR NOTES:

1. Substitution of equal concrete anchors from a different supplier may have different edge distance and center distance requirements.
2. Concrete anchor locations at the corners may be adjusted to maintain the min. edge distance to mortar joints. If concrete anchor locations noted as "MAX. ON CENTER" must be adjusted to maintain the min. edge distance to mortar joints, additional concrete anchors may be required to ensure the "MAX. ON CENTER" dimensions are not exceeded.
3. Concrete anchor table:

ANCHOR TYPE	ANCHOR SIZE	MIN. EMBEDMENT	MIN. CLEARANCE TO MASONRY EDGE	MIN. CLEARANCE TO ADJACENT ANCHOR
ITW	1/4"	1-1/4"	2-1/2"	3"
ELCO	1/4"	1-1/4"	1"	4"

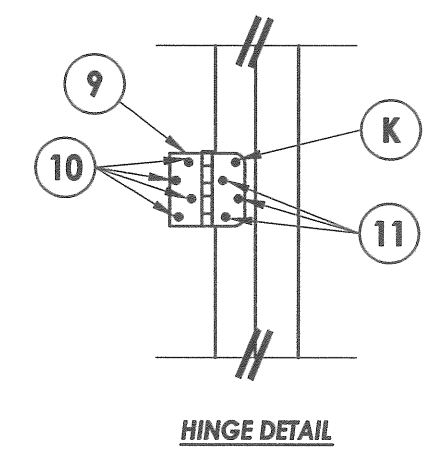

HINGE DETAIL

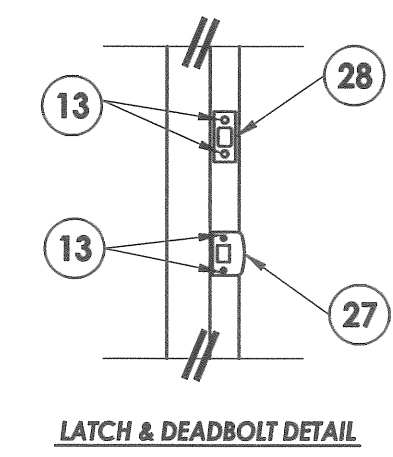

LATCH & DEADBOLT DETAIL

Documents Prepared By: **RW BUILDING CONSULTANTS, INC.**
 P.O. Box 230 Valrico FL 33595
 Phone No.: 813.659.9197
 Florida Board of Professional Engineers
 Certificate Of Authorization No. 9813
 Lyndon F. Schmidt, P.E. No. 43409
 Date: 2-17-12

PRODUCT: **PLASTPRO INC. FIBERGLASS DOOR**
 PART OR ASSEMBLY: **BUCK AND FRAME ANCHORING 2X BUCK MASONRY CONSTRUCTION**

NO.	DATE	BY	REVISIONS

DATE: 02/16/12
 SCALE: N.T.S.
 DWG. BY: JK
 CHK. BY: LFS
 DRAWING NO.: FL-15213.10
 SHEET 7 OF 9

© 2012 R.W. BUILDING CONSULTANTS INC.

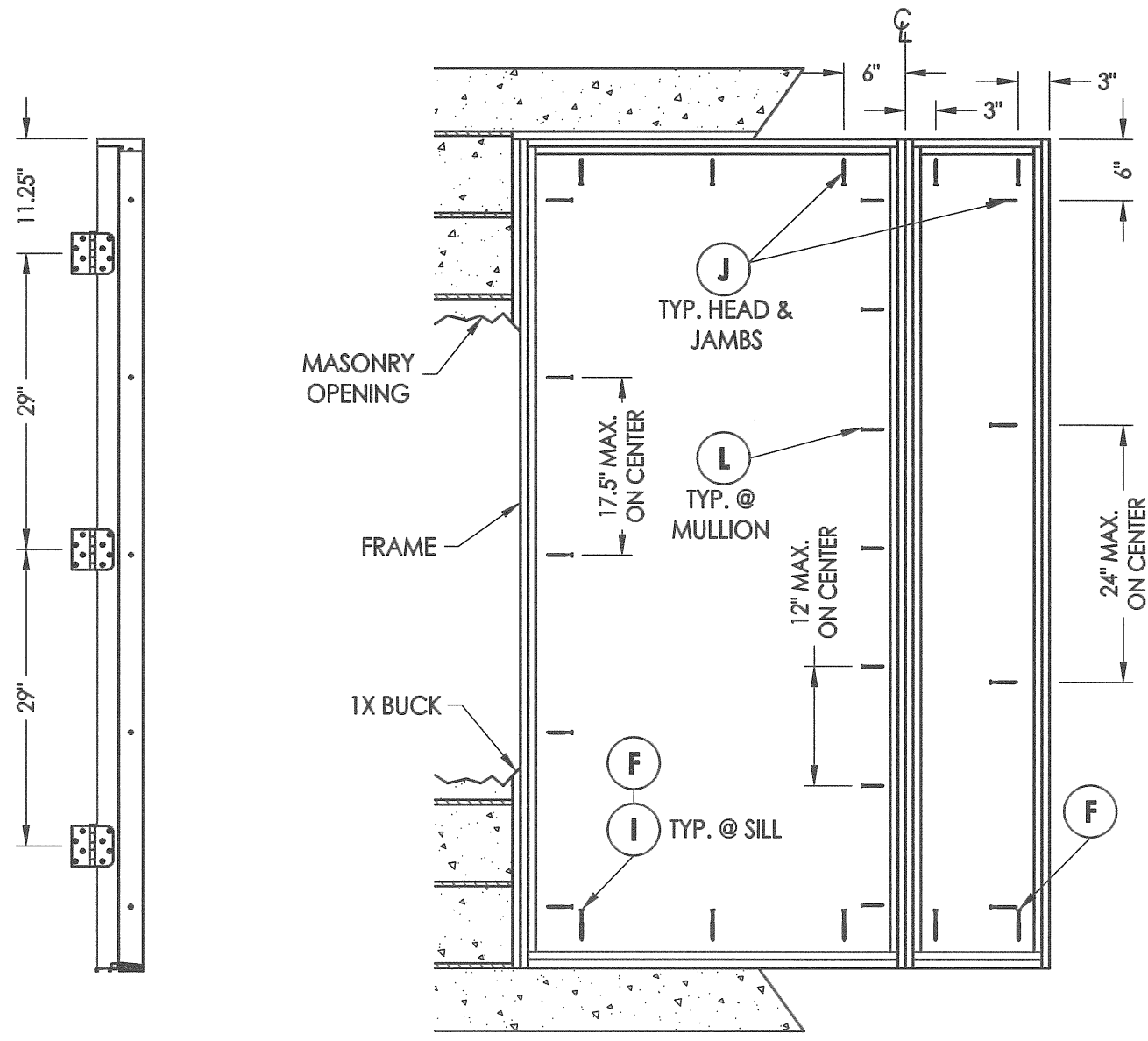

HINGE JAMB

FRAME ANCHORING
Masonry 1X buck construction

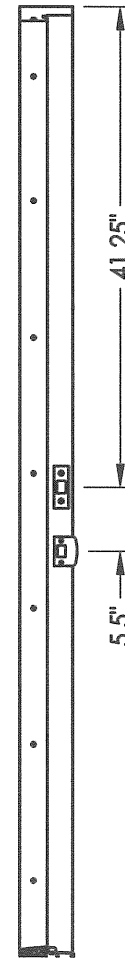

STRIKE JAMB

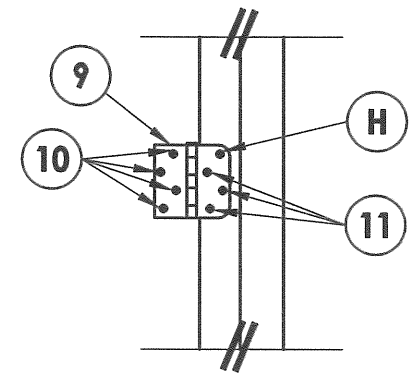

HINGE DETAIL

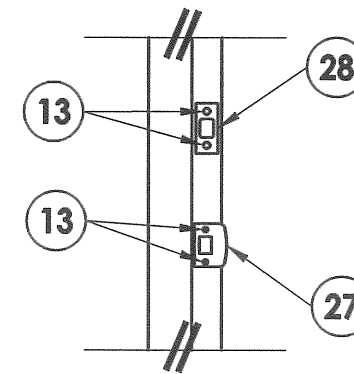

LATCH & DEADBOLT DETAIL

CONCRETE ANCHOR NOTES:

1. Substitution of equal concrete anchors from a different supplier may have different edge distance and center distance requirements.
2. Concrete anchor locations at the corners may be adjusted to maintain the min. edge distance to mortar joints. If concrete anchor locations noted as "MAX. ON CENTER" must be adjusted to maintain the min. edge distance to mortar joints, additional concrete anchors may be required to ensure the "MAX. ON CENTER" dimensions are not exceeded.
3. Concrete anchor table:

ANCHOR TYPE	ANCHOR SIZE	MIN. EMBEDMENT	MIN. CLEARANCE TO MASONRY EDGE	MIN. CLEARANCE TO ADJACENT ANCHOR
ITW	1/4"	1-1/4"	2-1/2"	3"

Documents Prepared By:

RW BUILDING CONSULTANTS, INC.
P.O. Box 230 Vairco FL, 33595
Phone No.: 813.659.9197
Florida Board of Professional Engineers
Certificate of Authorization No. 9813
LFS 2.17.12
Lyndon F. Schmidt, P.E. No. 43409

PRODUCT: PLASTIPRO INC. FIBERGLASS DOOR
PART OR ASSEMBLY: FRAME ANCHORING 1X BUCK MASONRY CONSTRUCTION

NO.	DATE	BY	REVISIONS

DATE: 02/16/12

SCALE: N.T.S.

DWG. BY: JK

CHK. BY: LFS

DRAWING NO.: FL-15213.10

SHEET 8 OF 9

R:\A - Projects\Project Folders\proj 1501 - 1600\PF 1587D - RWBC Drawings\2010\FL-15213.9-11.dwg, 9.10

BILL OF MATERIALS		
ITEM	DESCRIPTION	MATERIAL
A	1X BUCK SG >= 0.55	WOOD
B	2X BUCK SG >= 0.55	WOOD
C	1/4" MAX. SHIM SPACE	-
D	1/4" X 2-3/4" PFH ELCO OR ITW CONCRETE SCREW	STEEL
E	MASONRY - 3,192 PSI MIN. CONCRETE CONFORMING TO ACI 301 OR HOLLOW BLOCK CONFORMING TO ASTM C90	CONCRETE
F	1/4" X 2-3/4" PFH ITW CONCRETE SCREW	STEEL
H	1/4" x 3-1/4" PFH ITW CONCRETE SCREW	STEEL
I	1/4" X 2-1/4" PFH ITW CONCRETE SCREW	STEEL
J	1/4" X 3-3/4" PFH ITW CONCRETE SCREW	STEEL
K	#10 X 2" PFH WOOD SCREW	STEEL
L	#8 X 2-1/2" PFH WOOD SCREW	STEEL
M	#8 X 2" PFH WOOD SCREW	STEEL
7	FORCE 5 WEATHER STRIPPING BY ENDURA	FOAM
8	COMPRESSION WEATHER STRIP QLON 650 BY SCHLEGEL	FOAM
9	4" X 4" BUTT HINGE	STEEL
10	#9 X 1" PFH WOOD SCREW	STEEL
11	#9 X 3/4" PFH WOOD SCREW	STEEL
13	#8 X 1-1/2" PFH WOOD SCREW	STEEL
17	KWIKSET KEYED ENTRY - SIGNATURE SERIES	STEEL
18	KWIKSET DEADBOLT - SIGNATURE SERIES (780)	STEEL
20	FINGER JOINTED PINE FRAME, HEAD & HINGE JAMBS	WOOD
21	POLYFIBER JAMB	COMP. / VINYL
27	LATCH STRIKE PLATE	STEEL
28	DEADBOLT STRIKE PLATE	STEEL
30	INSWING VINYL DOOR BOTTOM SWEEP BY ENDURA	VINYL
31	OUTSWING BUMP THRESHOLD	ALUM.
32	VINYL DOOR BOTTOM SWEEP #3628 BY HOLM IND.	PVC
33	INSWING ADJUSTABLE THRESHOLD BY ENDURA	ALUM. / WOOD
34	INSWING ADJUSTABLE ALUMINUM THRESHOLD BY DLP	ALUM. / WOOD
35	SHOE MOULD 5/8" X 3/8"	WOOD
40	DOOR PANEL - SEE DOOR PANEL DETAIL SHEET FOR CONSTRUCTION DETAILS	-
41	DOOR SKIN (MIN. 0.075" THICK)	FIBERGLASS
42	TOP RAIL	CELLULAR PVC
43	LATCH & HINGE STILE	CELLULAR PVC
44	REINFORCEMENT WOOD FOR LOCKS (20" LONG)	WOOD
45	BOTTOM RAIL	CELLULAR PVC
46	POLYURETHANE FOAM BY NAN YA	POLYURETHANE
47	CONTINUOUS LATCH & HINGE STILE REINFORCEMENT	WOOD
48	SNAP IN LITE FRAME	ABS
49	GLAZING COMPOUND	SILICONE
50	SIDELITE PANEL - SEE SIDELITE PANEL DETAIL SHEET FOR CONSTRUCTION DETAILS	-
51	SIDELITE TOP & BOTTOM RAIL BY NAN YA	CELLULAR PVC
55	GLAZING SPACER	ALUM.

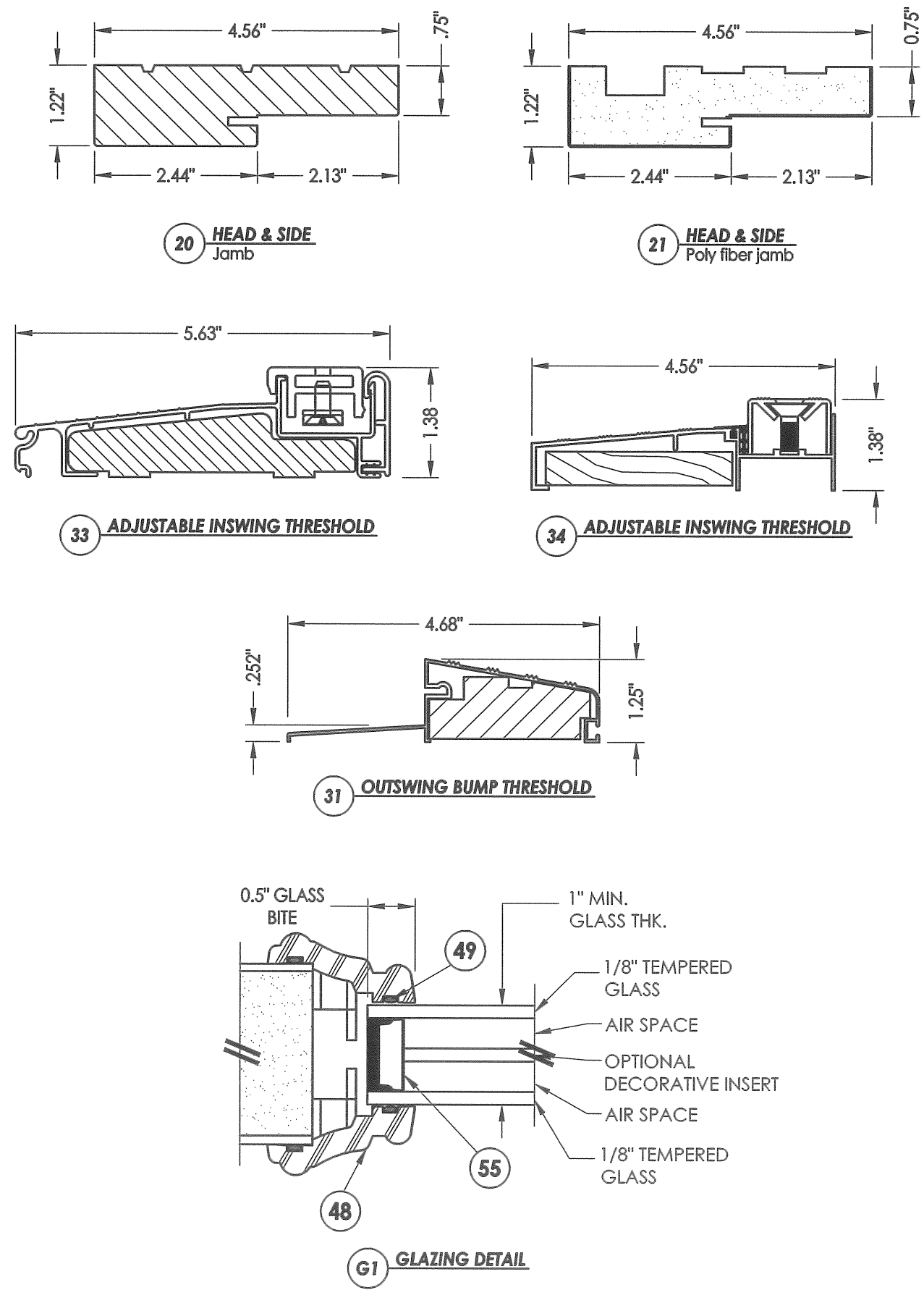

Documents Prepared By: **RW BUILDING CONSULTANTS, INC.**
P.O. Box 230 Valrico FL 33595
Phone No.: 813.659.9197
Florida Board of Professional Engineers
Certificate of Authorization No. 9813
LF
Lyndon F. Schmidt, P.E. No. 43409

PRODUCT: **PLASTPRO INC. FIBERGLASS DOOR**

PART OR ASSEMBLY: **BILL OF MATERIALS, GLAZING DETAIL & COMPONENTS**

NO.	DATE	BY	REVISIONS

DATE: 02/16/12
SCALE: N.T.S.
DWG. BY: JK
CHK. BY: LFS
DRAWING NO.: FL-15213.10
SHEET 9 OF 9

© 2012 R.W. BUILDING CONSULTANTS INC.